

850 T-5 TURBO

850 T-5 TURBO

850 T-5 TURBO

850 T-5 TURBO

850 T-5 TURBO



VOLVO



850 T-5 TURBO



VOLVO

Volvo Car UK Limited, Globe Park, Marlow, Buckinghamshire, SL7 1YQ
Telephone: 0628 477977 Facsimile: 0628 476173

VOLVO

PRESS INFORMATION

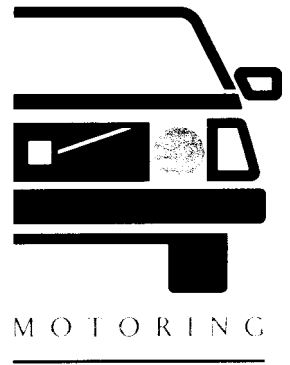

V93/BISS/32

October 1993

ALL TORQUE AND PLENTY OF ACTION

Volvo 850 Range Gains 225 bhp Turbo Performance Model

A unique combination of practicality and power is brought together in the swiftest ever production Volvo - the new 850 T-5 Turbo - which will make its UK debut at the London Motor Show at the end of October.

Developed from the widely-acclaimed front-wheel-drive Volvo 850, the new 2.3-litre, T-5 Turbo offers secure handling, driver enjoyment and readily available power for high performance enthusiasts who are looking for a more discreet option.

Packing a 225 bhp power punch from its five-cylinder, twenty-valve engine, the Volvo 850 T-5 Turbo is flexible in its power delivery with no less than 221 lb/ft of torque constantly available between 2,000 and 5,200 rpm.

With power always on offer, the T-5 driver can make smooth, swift progress up to a maximum speed of 149 mph, reaching 62 mph from rest in under 7.5 seconds. A torque limiter in first gear all but eliminates wheelspin.

Using modern turbocharging control and regulation techniques, Volvo engineers have also obtained the boost in power without sacrificing fuel economy.

In addition to the four door saloon model, Volvo is also introducing the 850 T-5 Turbo estate - a version which adds new meaning to "versatile performance" with a load space that stretches to 56 cubic feet.

ALL TORQUE AND PLENTY OF ACTION.../2

As ever, the award winning safety attributes of the Volvo 850 are retained with ABS braking, a driver's side airbag, Volvo's unique SIPS (Side Impact Protection System), three-point seatbelts for all occupants and the integral rear child seat ensuring that the car's performance potential is enjoyed in maximum safety.

Standard equipment levels are comprehensive with all 850 T-5 drivers enjoying the luxury of special Turbo plush/leather interior trim, power assisted steering, electric windows, electric sunroof and the stylish addition of five spoke alloy wheels and a subtle boot spoiler on the saloon.

But the price of the new models looks set to leave rival performance machines trailing in the T-5's wake; just £23,995 for the saloon and £24,795 for the estate models.

Says Volvo Car UK Limited's Managing Director, Charles Hunter-Pease: "The Volvo 850 has already established a new image for Volvo in terms of its driver appeal. With the T-5 we have added even more spice to the successful 850 recipe and have a performance car that is practical in everyday use."

On sale from the end of the month - only a strictly limited supply of Volvo 850 T-5 Turbos will be imported to the UK each year.

- ENDS -

For further information, please contact:

Roger Ormisher/Emily Payze
Volvo Car UK Limited
Globe Park
Marlow
Bucks SL7 1 YQ

Tel: 0628 477977

VOLVO

PRESS INFORMATION



V93/BISS/33

October 1993

VOLVO 850 T-5 TURBO

PRACTICAL PERFORMANCE

Since its UK launch - as Volvo's first front-wheel-drive executive saloon - in May 1992, the five-cylinder Volvo 850 has won worldwide acclaim for its driver appeal, safety features and all-round ability.

In total, the 850 boasts more than a dozen awards ranging from the USA to Japan, including "Best Large Car" Award 1993 from Britain's top-selling car magazine - Auto Express.

Stylish estate models, with their distinctive "stacked" rear lights were introduced in May 1993 and a competitively priced 2.5-litre, 10-valve version to pre-empt expected 1994 company car tax changes followed in September.

Now with the high-performance T-5 Turbo version the Volvo 850 competes in a whole new market sector - where image and driver appeal are primary buyer considerations.

The Marketplace

On performance terms alone the Volvo 850 T-5 Turbo is in very exclusive company when rivals are considered. BMW provides most of the competition and buyers for the car will be largely conquest customers.

VOLVO 850 T-5 TURBO PRACTICAL PERFORMANCE.../2

Generally a high mileage driver, the typical T-5 buyer will be a male executive, aged 25-45 years who enjoys driving and finds speed exhilarating. They are active, confident and ambitious individuals who lead a stylish and sophisticated lifestyle. Likely hobbies include active sports (squash, tennis), DIY, music and family.

Key factors in the car buying decision will be performance and excellent driveability.

Says Volvo Car UK's Marketing Director, Alexei Orlov: "We expect to sell no more than a couple of hundred 850 T-5 Turbos each year to discerning customers who are looking for useable performance in an understated but practical package."

Potent Powerplant

Refinement and flexibility were just as important as outright performance to the engineers who developed the powerplant for the Volvo 850 T-5 Turbo.

Derived from the transverse, five-cylinder unit that powers all models in the 850 range, the B5234T engine at the heart of the T-5 features a compact turbocharger. This smaller turbocharger cuts inertia in the impellers and allows the engine to reach maximum torque much faster.

With a displacement of 2,319cc, the four-valve per cylinder engine is derived from the 2.5-litre normally aspirated unit found in the 850 GLT.

This reduction in capacity has been achieved by reducing the bore to 81 mm (the **same as** that in the 2-litre unit) with the stroke remaining unchanged at 90 mm. The compression ratio is set at 8.5:1.

This reduction in capacity enables a larger space between the cylinders and so increased heat transfer - essential to achieve the higher cooling volume that is required in a turbocharged engine.

VOLVO 850 T-5 TURBO PRACTICAL PERFORMANCE.../3

Total output has been limited to 225 bhp at 5,300 rpm by Volvo engineers to ensure that it is converted into useable performance rather than needless wheelspin.

But the real ace up the T-5's sleeve is its torque curve, which enables the car to produce a maximum of 221 lb/ft all the way between 2,000 and 5,200 rpm - giving a seamless punch of power in the engine speed range where 90 per cent of driving takes place.

Throttle response is fast and distinct giving the T-5 driver feedback and a lack of turbo lag that makes both cross-country driving and city traffic just as hassle-free.

Intelligent Engine Control

Fuel and ignition systems are integrated in a new Motronic generation 4.3 engine management system that has extra capacity for turbo regulation and a sophisticated second generation OBD II diagnostics system that stores and memorises possible faults.

Electronic control of turbo boost pressure with adjustments for ambient atmospheric pressure, relative humidity and temperature is also controlled by the Motronic system - ensuring that the engine functions are optimised. Normal boost pressure is 1.66 kPa but boost pressure of 1.4 kPa is available from as low as 1,800 rpm: hence the T-5's excellent driveability.

For the T-5 the inlet manifold reverts to conventional type rather than the variable inlet (twin duct) system on standard 850 models.

Torque Limited For Smooth Starts

To enable clean starts from rest the torque in first gear has been limited to 191 lb/ft to eliminate wheelspin and get the power transferred directly onto the road in addition to keeping stresses on the transmission to a minimum.

VOLVO 850 T-5 TURBO PRACTICAL PERFORMANCE.../4

This gives both the T-5 saloon and estate models a 0-62 mph acceleration time of under 7.5 seconds on their way to a top speed of 149 mph.

Other modifications to the T-5 include reinforced internal shafts in the manual gearbox, a larger and more robust clutch and gearbox ratios that have been closed up between first, second and third gears to suit the turbo engine's power delivery.

A four-speed electronic automatic gearbox is available with three different settings: sport, economy and winter. Final drive ratio is 4.00:1 in manual versions and 2.54:1 in automatic models.

Secure Handling

The sophisticated chassis layout of the standard Volvo 850 is retained in the T-5 Turbo but with the addition of stiffer gas shock absorbers all round and uprated anti-roll bars.

This means that the dynamic handling characteristics for which the 850 has become renowned are enhanced in the T-5 which sports MacPherson strut front suspension, Volvo's unique Delta-link rear suspension, has excellent feedback from its standard power steering and the back-up of a powerful ABS braking system as standard.

In fact, the Delta-link rear suspension also permits a certain degree of "rear wheel steer" - a feature that results in predictable handling and excellent stability under cornering.

Stylish five-spoke, 6.5" x 16" alloy wheels distinguish the T-5, and are fitted with 205/50ZR - 16 tyres for excellent traction in all conditions.

For the ultimate in grip, T-5 customers can order spectacular optional 7" x 17" alloy wheels with five totally flat spokes fitted with specially developed Pirelli P Zero ultra-low profile tyres.

VOLVO 850 T-5 TURBO PRACTICAL PERFORMANCE.../5

An optional chassis lowering kit stiffens the suspension further and lowers the ride height by 20 mm for an even sportier stance.

Safety Firsts

The award-winning safety features of the standard Volvo 850 are retained in the T-5, ensuring that the car's sporting characteristics can be enjoyed with the maximum peace of mind. These include:

- driver's side, full size (67-litre) airbag
- seatbelt pretensioners
- Volvo's unique SIPS (Side Impact Protection System) which absorbs crash energy and transfers it away from the car's occupants
- three-point seatbelts for all five occupants including the central rear seat position
- integral child seat in the middle of the rear seat
- front seatbelt reels that automatically adjust to the occupant's shoulder height
- front and rear seat design that prevents "submarining"

Smoother Styling

The launch of the T-5 Turbo marks the first external changes made to the 850 range since its original launch two years ago.

New front and rear bumpers and sleeker headlamps give the car a smoother, more rounded look. A re-designed front spoiler integrates with the bumper and includes housings for extra driving lights.

The new headlamps have double "complex shape" reflectors which give considerable improvements in lighting on both dip and main beam.

A subtle rear spoiler for the T-5 Turbo saloon completes the picture along with a new red pearlescent paint option - a colour that emphasises the T-5's fiery nature.

VOLVO 850 T-5 TURBO PRACTICAL PERFORMANCE.../6

New Upholstery

Inside the T-5 the dashboard layout mirrors that of the standard Volvo 850 models with its clear instrumentation and switches and controls that fall easily to hand. A turbo pressure gauge is added and the speedometer re-calibrated.

A special "turbo" upholstery is also featured on the T-5, which combines discreetly patterned plush velour with leather edging.

Standard equipment on the T-5 is comprehensive and includes power steering, central locking, adjustable steering column, heated and electrically adjustable door mirrors, electric windows all round, trip computer, stereo radio cassette recorder with RDS, an electric glass sunroof and alloy wheels.

Options include air conditioning, cruise control, electric seat adjustment, burr walnut dashboard, traction control and a suspension lowering kit can be added to personalise the T-5 to a customer's individual requirements.

Lower Ownerships Costs

Apart from its very competitive initial purchase price (£23,995 saloon and £24,795 estate), the 850 T-5 offers traditional Volvo reliability and durability.

Coming with a 12-month, unlimited mileage warranty and full one year RAC cover, the T-5 only requires servicing at 10,000 mile/12 month intervals.

Fuel consumption for this type of performance car is also low, with the T-5 returning the following results:

Urban	21.0 mpg
Constant 56 mph	40.9 mpg
Constant 75 mph	33.2 mpg

VOLVO 850 T-5 TURBO PRACTICAL PERFORMANCE.../7

And the T-5 tackles worries about insurance premiums head-on by being classed in Group 15, with the Volvo Owners' Insurance Scheme offering further discounts for certain categories of driver.

- ENDS -

For further information, please contact:

Roger Ormisher/Emily Payze
Volvo Car UK Limited
Globe Park
Marlow
Bucks SL7 1YQ

Tel: 0628 477977

TECHNICAL SPECIFICATIONS

ENGINE OPTIONS

CAR TYPE	850		850		850		850		950	
	SE 2.0		GLT 2.0		SE 2.5		GLT 2.5		TURBO	
Engine	B5204F		B5204F		B5252F		B5254F		B5234F	
Configuration	Transverse - 20 valve		Transverse - 20 valve		Transverse - 10 valve		Transverse - 20 valve		Transverse - 20 valve	
Cylinders	5		5		5		5		5	
Bore x stroke (mm)	81/77		81/77		83/90		83/90		81/90	
Engine capacity (cc)	1984		1984		2435		2435		2319	
Max output ECE (hp/rpm)	143/6500		143/6500		140/5400		170/6200		225/5200	
Max. torque ECE (Nm/rpm)	176/3800		176/3800		206/3600		220/3300		300/2000-5200	
Octane rating	95 unleaded*		95 unleaded'		95 unleaded'		95 unleaded'		95 unleaded'	
Fuel system	Microprocessor- controlled adaptive system and diagnostic unit (LH Jetronic)		Microprocessor- controlled adaptive system and diagnostic unit (LH Jetronic)		Combined fuel/ ignition system (Siemens). Microprocessor- controlled with diagnostic unit		Microprocessor- controlled adaptive system and diagnostic unit (LH Jetronic)		Combined fuel/ ignition system (Motronic 4.3) Microprocessor with diagnostic unit	
Exhaust system	Catalytic converter with Lambda sond		Catalytic converter with Lambda sond		Catalytic converter with Lambda sond		Catalytic converter with Lambda sond		Catalytic converter with Lambda sond	

FUEL TANK

Volume (litres/gallons)	73/16		73/16		73/16		73/16		73/16	
-------------------------	-------	--	-------	--	-------	--	-------	--	-------	--

TRANSMISSION

Automatic	4 Speed inc. O.D. mode selector		4 Speed inc. O.D. mode selector		4 Speed inc. O.D. mode selector		4 speed inc. O.D. mode selector		4 speed inc. O.D. mode selector	
Manual	5 speed		5 speed		5 speed		5 speed		5 speed	

STEERING SYSTEM (rack & pinion)

Power assisted	●		●		●		●		●	
Turning circle	10.2 m		10.2 m		10.2m		10.2 m		10.6m	
Tyre size	185/65		195/60		185/65		195/60		205/50	

PERFORMANCE

	Saloon		Estate		Saloon		Estate		Saloon		Estate	
Top speed (mph)	125	124	125	124	127	127	131	131	149	149		
Acceleration 0-62 mph (s)	10.8	11.2	10.9	11.2	10.3	10.5	9.3	9.5	7.4	7.5		

TECHNICAL SPECIFICATIONS

CAR TYPE	850 SE 2.0		850 GLT 2.0		850 SE 2.5		850 GLT 2.5		a50 TURBO	
WEIGHTS (approx)										
Av. Kerb weight (kg)	1455	1451	1469	1456	1401	1449	1479	1460	1436	1487
Max. permissible towing weight (kg)	1600	1600	1600	1600	1600	1600	1600	1600	1600	1600
Max. recommended towing weight (kg)	1236	1238	1248	1237	1191	1232	1257	1241	1221	1264
Optimum/Max. nose weight (kg)	50/75	50/75	50/75	50/75	50/75	50/75	50/75	50/75	50/75	50/75
LUGGAGE COMPARTMENT										
Volume (cu. ft.)	14.7	28	14.7	28	14.7	28	14.7	28	14.7	28
Volume rear seats down (cu.ft.)	32.2	56	32.2	56	32.2	56	32.2	56	32.2	56

Please note: You must only use unleaded petrol in a car equipped with a catalytic converter.

Data valid for manual transmission.

• Standard

Dimensions in cm. N.B. Interior dimensions do not include sunroof.

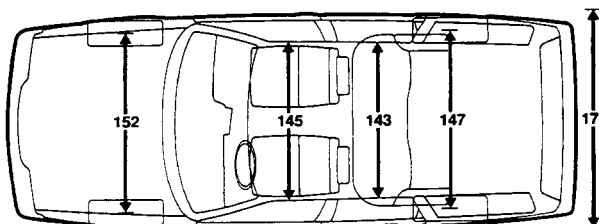
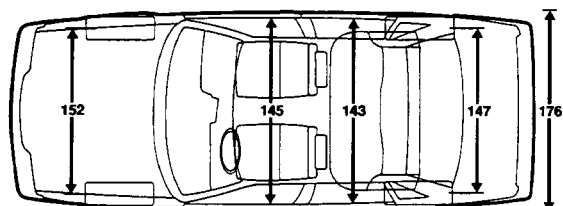
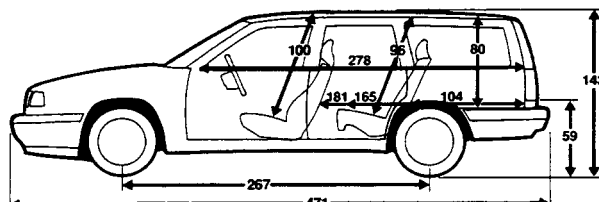
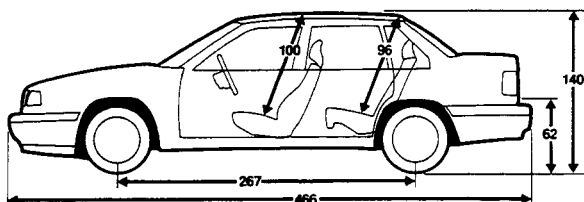

Warranty: 12 Months warranty - unlimited mileage. 12 months RAC cover - please ask your dealer for details.

The information, specification and illustrations relating to the models described in this brochure, may be different in respect of similar vehicles currently on sale in the UK. When making enquiries about any vehicle, please ask your Volvo Dealer to advise you of any differences from the specifications which are contained in the brochure. Specifications may differ in the Republic of Ireland.

In the interest of continuing product development, the factory reserves the right to make changes at any time, without notice, to prices, colours, materials, equipment or specifications and also to discontinue models.

STANDARD AND OPTIONAL EQUIPMENT

CAR TYPE	850 SE	850 GLT	850 TURBO
COMFORT			
Automatic transmission	○	○	○
Power steering	●	●	●
Central locking	●	●	●
Remote central locking	○	○	○
Cruise control	○	○	○
Adjustable steering column - height/reach	●	●	●
Leather steering wheel	○	○	○
Electrically adjustable passenger door mirror	●	●	●
Electrically adjustable driver's door mirror	-	●	●
Electric windows-front	●	●	●
Electric windows - rear	○	○	●
Air conditioning	○	○	○
Automatic climate control	○	○	○
INTERIOR			
Cloth upholstery	●	-	-
GLT upholstery	-	●	-
Turbo upholstery	-	-	●
Leather-faced upholstery	○	○	○
Driver's seat electric adjustment (with memory)	○	○	○
Passenger seat electric adjustment (with memory)	◆	○	○
Trip computer	○	○	●
Height adjustable front seats with lumbar support	●	●	●
Heated front seats	●	●	●
Forward folding front passenger seat backrest	●	●	●
Folding split rear seats	●	●	●
3 band RDS stereo radio/cassette CR905	●	●	-
3 band RDS stereo radio/cassette SC800	-	-	●
Electric aerial (saloons only)	●	●	●
Integral aerial in rear side window (estates only)	●	●	●
Lockable glove box	●	●	●
Tachometer	●	●	●
Front and rear reading lights	●	●	●
Separate instep lighting	●	●	●
Load cover (estates only)	●	●	●
Burr walnut dashboard	○	○	○
Underfloor storage compartment (estates only)	●	●	●
Load eyes in luggage compartment (estates only)	●	●	●

- Standard Equipment
- Optional Equipment at extra cost
- Optional Equipment available at no extra cost
- Not available

◆ Available in conjunction with electric driver's seat only.

❖ Available with manual transmission 850s only. Not available with load compensating suspension until mid October 1993.

♣ Available in conjunction with ABS only.

The information, specification and illustrations relating to the models described in this brochure, may be different in respect of similar vehicles currently on sale in the UK. When making enquiries about any vehicle, please ask your Volvo dealer to advise you of any differences from the specifications which are contained in the brochure. Specifications may differ in the Republic of Ireland.

STANDARD AND OPTIONAL EQUIPMENT

CAR TYPE	850 SE	850 GLT	850 TURBO
EXTERIOR			
Manual steel sunroof	●	-	-
Electric glass sunroof	-	●	●
Metallic paint	○	○	○
Tinted windows	●	●	●
Heated rear window	●	●	●
Deadlocks (on all 4 doors and boot/tailgate)	●	●	●
Delta-link independent rear suspension	●	●	●
Wheel covers	●	-	-
6 spoke 15" alloy wheels (195/60 VR tyres)	-	●	-
24 spoke 15" alloy wheels (195/60 VR tyres)	○	-	-
5 spoke 16" alloy wheels (205/50 ZR tyres)	-	-	●
185/65 HR tyres	●	-	-
205/55 VR tyres	-	○	-
Colour co-ordinated bumpers and mirrors	-	●	●
Key operated burglar alarm	●	●	●
Boot lid spoiler (saloon only)	○	○	●
Catalytic converter with Lambda sond	●	●	●
Roof rails (estates only)	○	○	○
Suspension lowering kit	❖	○	○
SAFETY			
Driver's side airbag - SRS	●	●	●
Anti-lock brakes (ABS)	●	●	●
TRACS (Traction Control System)	○	○	○
SIPS - Side Impact Protection System	●	●	●
Laminated windscreen	●	●	●
Heated door mirrors	●	●	●
High level rear brake light	●	●	●
Front seat belt pretensioners	●	●	●
Automatic front seat belt height adjustment	●	●	●
Integrated childseat in rear centre armrest	●	●	●
Head restraints front & rear (5 in total)	●	●	●
3-point inertia reel seat belts for all five seating positions	●	●	●
Childproof locks in rear doors	●	●	●
Rear fog light & hazard warning lights	●	●	●
Permanent dim/dip headlights	●	●	●
Headlamp wash/wipe	●	●	●
Rear screen wash/wipe (estates only)	●	●	●
External temperature gauge (including ice alert)	○	●	●
Load compensating rear suspension - saloons	○	○	○
Load compensating rear suspension - estates	○	○	●
Luggage net (estates only)	○	○	○

PACKAGE OPTIONS:

Luxury Option Pack (available on SE and GLT):

Air Conditioning, Electric Rear Windows and Trip Computer
(air conditioning replaces sunroof except on GLT 2.5)

Estate Option Pack (available on SE and GLT estates):

Load Compensating Suspension, Roof Rails and Luggage Net

The Luxury and Estate option packs can be combined on the 850 SE and GLT estates.

- (1) Exhaust manifold
- (2) Turbocharger
- (3) Pressure regulator
- (4) Link
- (5) Relief valve
- (6) Oil inlet
- (7) Cooling water inlet
- (8) Cooling water return
- (9) Flexible joint

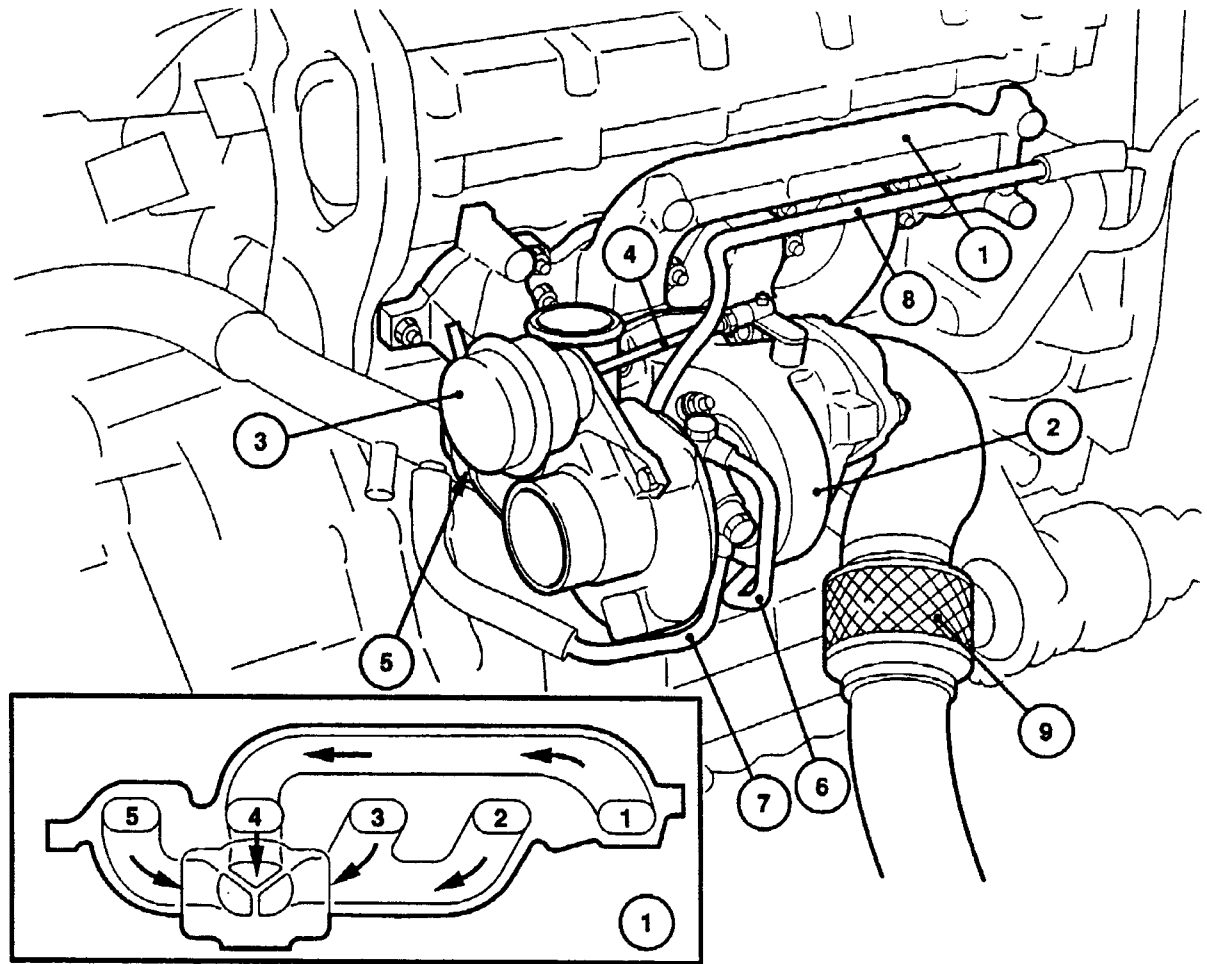

Volvo 850 Turbo (T-5) Exhaust manifold and turbocharger

VOLVO

- (1) Control module
- (4) Mass air flow sensor
- (5) Engine temperature sensor
- (9) Knock sensor
- (11) Automatic transmission control modul

- (23) Turbo control valve
- (A) Turbocharger
- (B) Wastegate valve

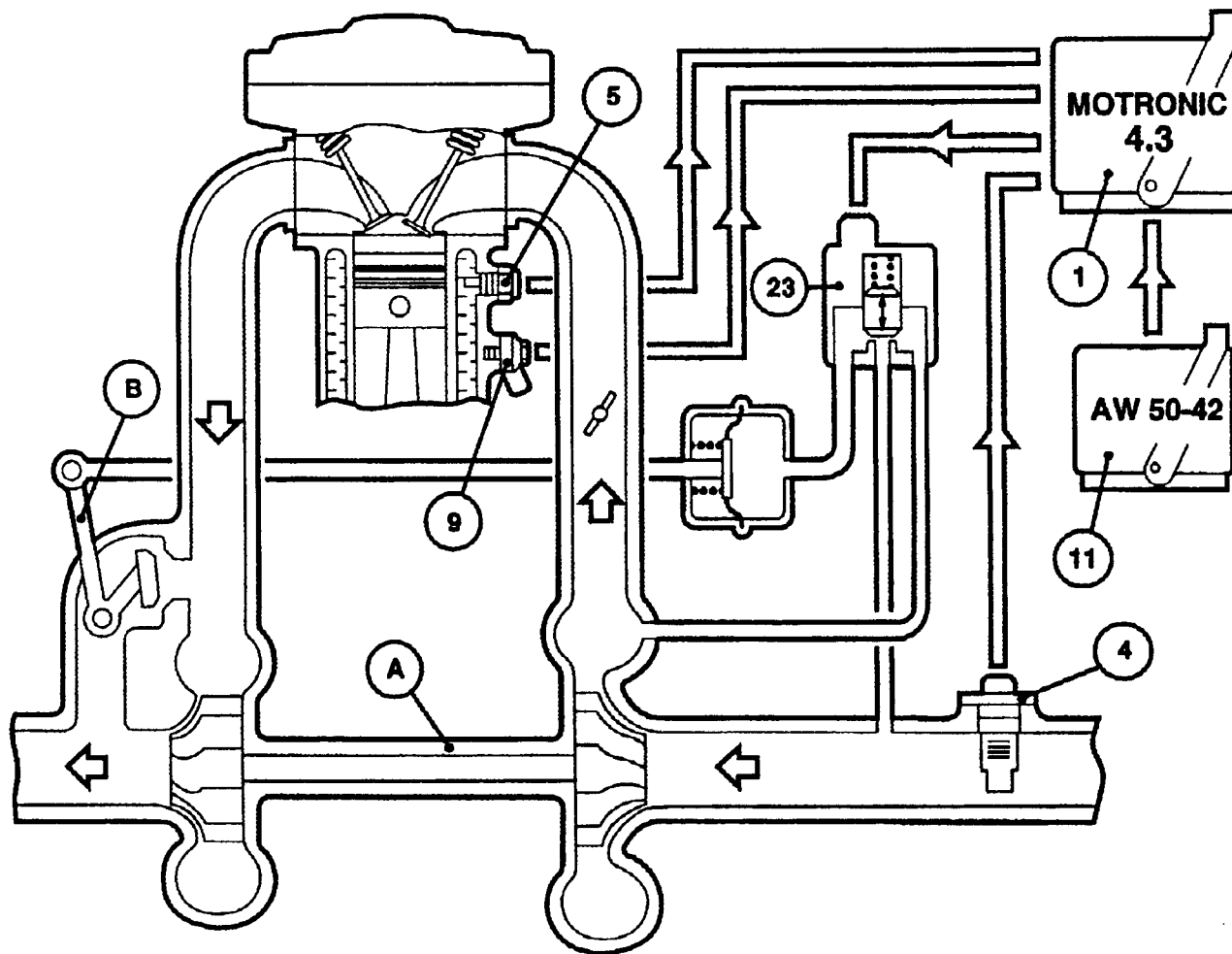

Volvo 850 Turbo (T-5) Turbo Control System

VOLVO

Power

Torque

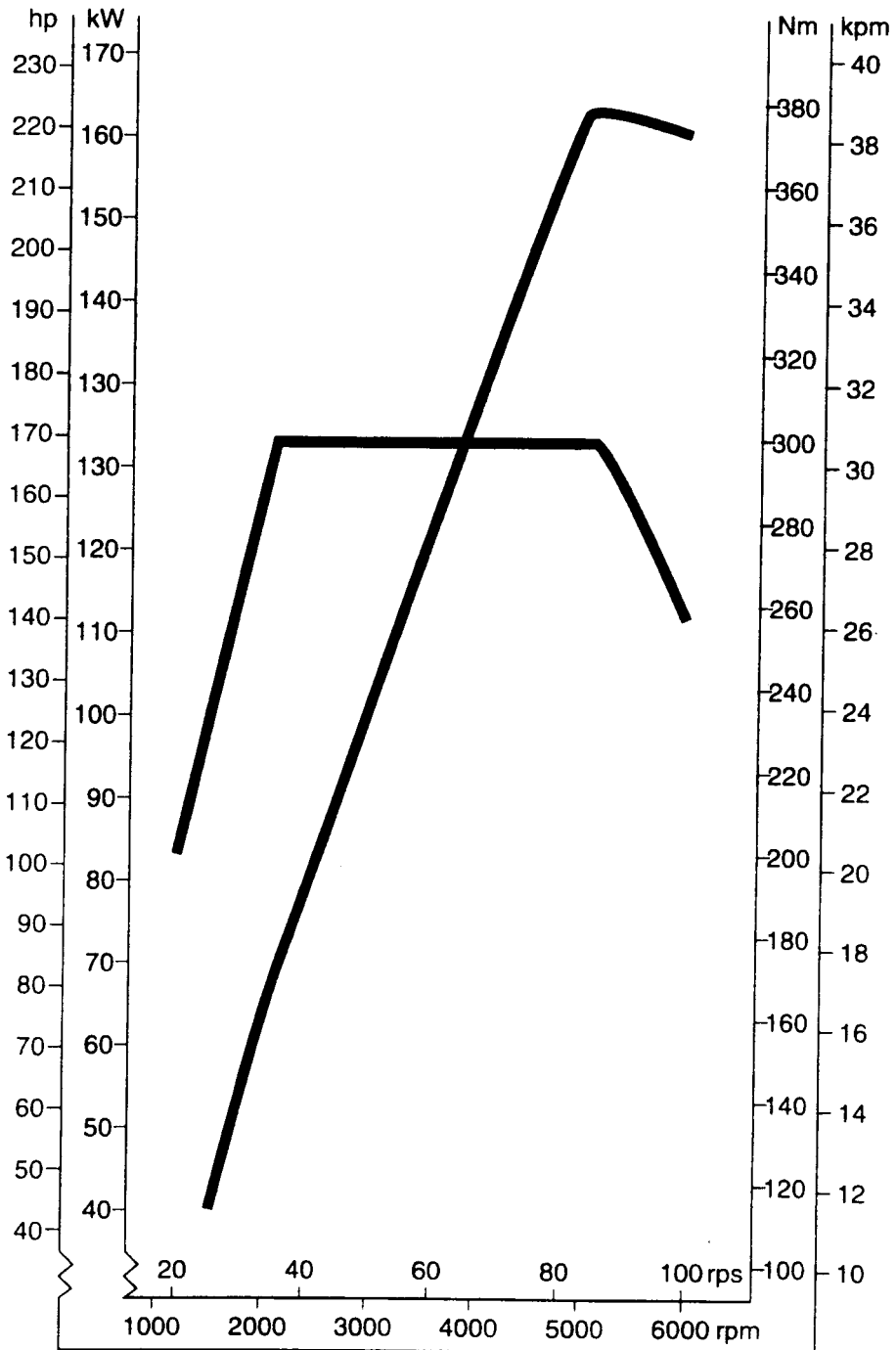

Volvo 850

Turbocharged B5234T engine

VOLVO